



Remote control supplied.

## LO-LINE RC & LO-LINE RC Heater/Cooler.

The **LO-LINE RC** fan convector is quick to heat giving convenient and instant warmth just when you need it, as well as a refreshing cooling option with the heater/cooler model for the summer months. **LO-LINE RC** units connect to the central heating system (water chilling equipment is also required for the heater/cooler model) and are fitted at a similar height to a standard radiator. The accompanying remote control offers maximum control and flexibility.



### System Design for Fan Convectors

Fan convectors are intended to be connected to central heating systems in the same way as radiators, and offer advantages and benefits not available from traditional emitters. To ensure optimum fan convector performance, great care must be taken to ensure that the choice of unit and the heating system design are considered. The following factors must be taken into consideration:

- Fan convectors should only be used on closed circulation, two pipe, pump assisted central heating systems.
- Fan convectors should be correctly sized to match the heat loss requirement of the room with the unit operating at its lowest fan speed.
- The heating system must be capable of providing sufficient hot water through the heat exchanger. This means that:
  - The minimum pipe size should be 15mm.
  - Fan convectors are not suitable for use on microbore pipe-work.
  - Fan convectors are not suitable for one-pipe systems.
  - Where the unit is fitted onto a system with other emitters, a separate circuit for the fan convector should be considered to ensure an adequate water flow through it.
- The heating system water temperature must be greater than 43°C in heating mode for the unit to operate (lower temperatures possible for heat pump applications on wall mounted units).
- Optimum performance of the fan convector will require effective balancing of the whole system.
- Fan convectors should not be used to replace radiators in existing systems unless pipe-work sizing, system design and system balancing can guarantee an adequate flow of water through the fan convector.
- The maximum working pressure through the heat exchanger is 10 bar (150 lb/in<sup>2</sup>). The maximum allowable water temperature through the heat exchanger is 90°C.
- Wall mounted units should be mounted on a flat wall, and stud or partition walls should be avoided to minimise the possibility of noise transmission.

**LO-LINE RC Performance Data**

It is preferable to select the model with an output capable of maintaining the calculated heat losses of the room when operating at normal speed. The higher fan speeds will be used automatically when the room temperature is significantly lower

than the preset temperature. When establishing the temperature difference, i.e. mean water to room temperature, allowance should be made for temperature drop in the system. It is the temperature at the convector which dictates the output.

**Heating Performance Data**

Model	Fan Speed	Temperature Difference (°C)									
		Heat Output (watts)					Heat Output (Btu/h)				
		20°	30°	40°	50°	60°	20°	30°	40°	50°	60°
19-15	Normal	1509	2221	2921	3613	4298	5150	7578	9967	12327	14665
	Medium	1731	2548	3351	4144	4930	5907	8692	11432	14140	16822
	Boost	1938	2852	3751	4640	5520	6613	9731	12799	15831	18834
14-10	Normal	993	1461	1922	2377	2828	3388	4986	6558	8111	9649
	Medium	1223	1800	2367	2928	3483	4173	6140	8076	9989	11884
	Boost	1448	2131	2803	3467	4124	4942	7272	9564	11829	14073
9-6	Normal	567	834	1098	1358	1615	1935	2847	3745	4633	5512
	Medium	743	1093	1437	1777	2114	2534	3728	4903	6064	7213
	Boost	936	1377	1811	2240	2665	3194	4699	6180	7643	9092
6-4	Normal	383	564	741	916	1090	1307	1923	2528	3126	3718
	Medium	436	641	843	1043	1241	1486	2187	2876	3558	4233
	Boost	600	883	1162	1437	1710	2049	3014	3965	4904	5834

Heat outputs tested in accordance with BS 4856 Part 1.

**Flow Rate:** 340 ltr/h (75 gal/h).

For combined heating and cooling applications, a suitable chilled water source and associated controls must be provided and installed, in accordance with the recommendations of the chiller manufacturer.

Provision must be made for condensate disposal, in accordance with any local regulations. A condensate collection tray is fitted

**Flow Rate Correction Factors:**

455 ltr/h (100 gal/h) multiply output by 1.06.

227 ltr/h (50 gal/h) multiply output by 0.96.

113 ltr/h (25 gal/h) multiply output by 0.85.

and a suitable drain pipe should be connected to the spigot (15mm) at the base of the condensate tray.

Thermostatic control for cooling may be achieved by connection of a thermostat into the mains supply to the unit.

All pipework must be wrapped with anti-condensate material 5-10mm thick.

**Cooling Performance Data (Heater/Cooler Model Only)**

Model	Fan Speed	Temperature Difference (°C)											
		Cooling Performance (watts)						Cooling Performance (Btu/h)					
		15°		20°		25°		15°		20°		25°	
		Tot.	Sens.	Tot.	Sens.	Tot.	Sens.	Tot.	Sens.	Tot.	Sens.	Tot.	Sens.
19-15	Normal	1340	1104	2002	1345	2734	1452	4572	3767	6831	4589	9328	4954
	Medium	1464	1203	2187	1511	2987	1632	4995	4105	7462	5156	10192	5568
	Boost	1533	1305	2291	1656	3128	1725	5231	4453	7817	5650	10673	5886
14-10	Normal	877	754	1310	969	1788	1034	2992	2573	4470	3306	6101	3528
	Medium	1032	878	1542	1113	2106	1159	3521	2996	5261	3798	7186	3955
	Boost	1228	1052	1835	1347	2505	1427	4190	3589	6261	4596	8547	4869
9-6	Normal	499	423	745	535	1018	553	1703	1443	2542	1825	3473	1887
	Medium	600	507	896	639	1223	655	2047	1730	3057	2180	4173	2235
	Boost	710	581	1061	770	1448	957	2423	1982	3620	2627	4941	3565
6-4	Normal	321	277	480	357	655	383	1095	945	1638	1218	2235	1307
	Medium	391	335	585	429	798	454	1334	1143	1996	1464	2723	1549
	Boost	496	397	741	526	1012	654	1692	1355	2528	1795	3453	2231

Cooling performance tested in accordance with BS 4856 Part 2.

**Flow Rate:** 340 ltr/h (75 gal/h).

**Relative Humidity:** 50%.

**Flow Rate Correction Factors:**

455 ltr/h (100 gal/h) multiply output by 1.06.

227 ltr/h (50 gal/h) multiply output by 0.96.

113 ltr/h (25 gal/h) multiply output by 0.85.

**LO-LINE RC Performance Data (continued)**

**Approximate Hydraulic Resistance**

Litres	mm wg				kPa			
	6-4	9-6	14-10	19-15	6-4	9-6	14-10	19-15
455	910	998	1240	1670	8.98	9.85	12.20	16.40
340	514	520	719	954	5.06	5.10	7.00	9.40
227	235	121	324	469	2.35	1.18	3.20	4.60
113	47	97	75	77	0.45	0.97	0.75	0.82

**Weight, Water Content and Motor Power**

Model	Motor Power (W)	Water Content (l)	Unpacked Weight (kg)
19-15	80	0.75	15.7
14-10	62	0.56	12.7
9-6	35	0.32	9.1
6-4	35	0.3	7.7

**LO-LINE RC Controls**

Units are supplied with an electronic infra-red remote control system with the following features:

- Automatic room temperature control.
- Fan only option for ambient air circulation.
- Three fan speeds.
- Unit mounted controls and display.
- Unit control panel electronic tamper proof lock.
- Displayed temperature calibration system.

**Noise Levels**

Model	Sound Pressures at 2.5m (dBA)		
	Normal	Medium	Boost
19-15	27.2	31.8	38.6
14-10	23.1	28.5	40.1
9-6	21.6	29.6	38
6-4	23.7	31.7	40.7

Noise levels tested in accordance with EN 23741.

**Air Flow**

Model	Air Flow (m <sup>3</sup> /h)			Air Flow (ft <sup>3</sup> /h)		
	Normal	Medium	Boost	Normal	Medium	Boost
19-15	241	288	335	8507	10166	11826
14-10	160	200	288	5648	7060	10166
9-6	112	129	175	3954	4554	6178
6-4	65	86	122	2295	3036	4307

**LO-LINE RC Water Connections**

Water connections (15mm compression) are on the left-hand side and the system pipework may be brought in from underneath or the rear.

**LO-LINE RC Electrical Data**

All LO-LINE models require an electrical supply of 220-240V – 50Hz fused at 3A.

**LO-LINE RC Dimensions and Fixings**

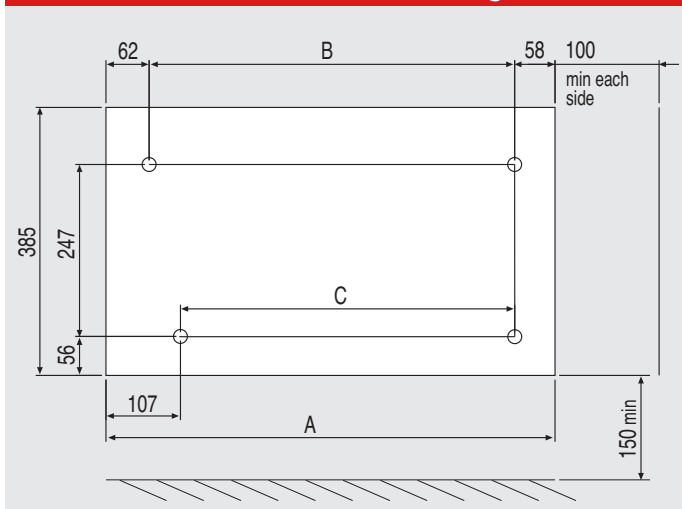

Model	Dimensions (mm)		
	A	B	C
19-15	1138	1018	974
14-10	854	733	681
9-6	645	526	481
6-4	523	404	359

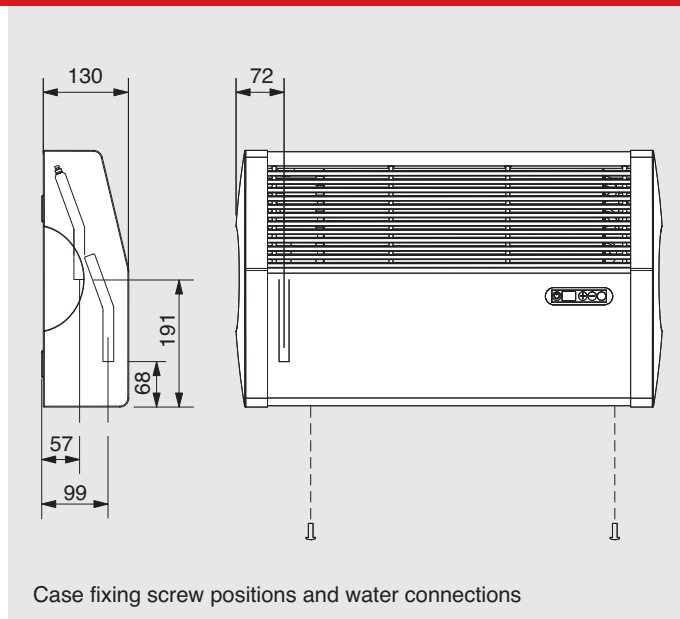

Case fixing screw positions and water connections

- Minimum installation height is 150mm to the underside of the unit.
- Maximum ceiling height is 3m.
- Minimum side clearance is 100mm.