

monsoon

Universal Single Pumps

Monsoon Universal pumps remove the guesswork from pump selection. Fully automatic, they will function under both positive and negative head conditions and are suitable for installation into an open vented hot and cold water system. Universal Monsoon pumps do not require a gravity flow of water to start.

Universal single pumps can be used in pairs to boost hot and cold water supplies independently, or as a single pump to boost a water supply as required.



Features

- Robust brass construction
- 2.0 - 4.5 bar performance options
- Continuously rated
- Hard faced nitrile/carbon/silicon carbide seal
- G 3/4 threaded connections
- Pre-wired with 1.5 metre power cable
- Anti-vibration feet
- 5 year guarantee (subject to conditions)
- **UK Specification:** Supplied with 22 mm push-in x 300 mm anti-vibration flexible hoses with integral isolating valves
- **ROI Specification:** Supplied with 21 mm push-in x 300 mm anti-vibration flexible hoses with integral isolating valves
- **Export Specification:** Supplied with G 3/4 female x 300 mm long hoses

Application

- Boosting a hot water service to a common mixer where the cold supply is mains fed.
- Boosting hot and cold supplies separately.
- Increasing water pressure to a combi boiler via a break tank.

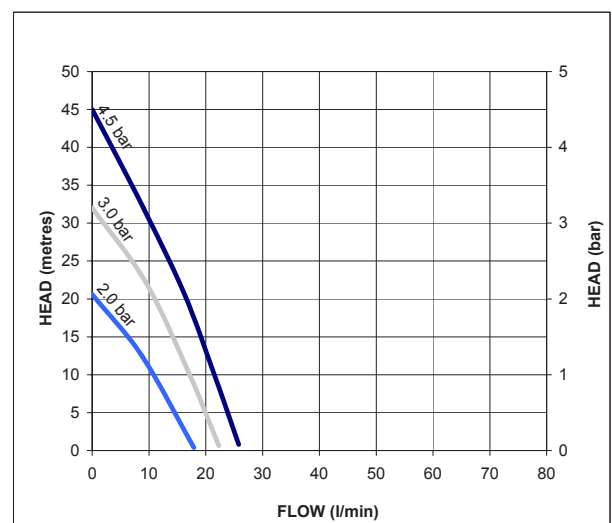

monsoon

Pump Model		U2.0 bar Single 46498	U3.0 bar Single 46413	U4.5 bar Single 46414
General	Guarantee	5 years		
	WRAS approval	1404701		
Features	Pump type	Peripheral		
	Mechanical seal	Nitrile / Carbon / Silicon Carbide		
	Anti-vibration feet	✓	✓	✓
	Inlet strainer(s)	✓	✓	✓
	Flexible hoses	2	2	2
	Run on Timer	3 sec	3 sec	3 sec
	Dry run protection	✓	✓	✓
Performance	Maximum head (closed valve)	2.0 bar	3.2 bar	4.5 bar
	Performance @ 9 l/min	1.2 bar	2.5 bar	3.5 bar
	Performance @ 18 l/min	N/A	0.9 bar	1.7 bar
	Maximum flow	18 l/min	22 l/min	26 l/min
	Maximum static inlet pressure	8 metres	12 metres	
	Maximum static outlet pressure	8 metres	12 metres	
	Maximum working pressure*	600 kPa (6 bar)		
	Maximum ambient air temperature	40 °C		
	Min / Max water temperature**	Min 4 °C / Max 65 °C		
	Flow switch sensitivity (approx)	0.6 l/min		
	Pressure vessel air pre-charge	0.9 bar (13 psi)	1.3 bar (18.5 psi)	
Connections	Pump connections	G 3/4 male		
Flexible hoses	Connections (UK model)	G 3/4 female x 22 mm push-in x 300 mm long, isolating valves on all hoses		
	Connections (ROI model)	G 3/4 female x 21 mm push-in x 300 mm long, isolating valves on all hoses		
	Connections (Export model)	G 3/4 female x G 3/4 female x 300 mm long		
Motor	Type	Induction, auto-reset thermal trip		
	Duty rating	Continuous (S1) @ 9 l/min and above		
Electrical	Power supply / phase / frequency	230 V a.c. / 1 / 50 Hz		
	Current (full load)	1.1 Amps	1.7 Amps	2.5 Amps
	Power consumption	250 Watts	390 Watts	555 Watts
	Fuse rating	5 Amps		
	Power cable (pre-wired)	1.5 metres		
Physical	Enclosure protection	IPX4		
	Length	200 mm		
	Width	162 mm		
	Height (excluding hoses)	243 mm		
	Weight (including fittings)	6.6 Kg		7.3 Kg

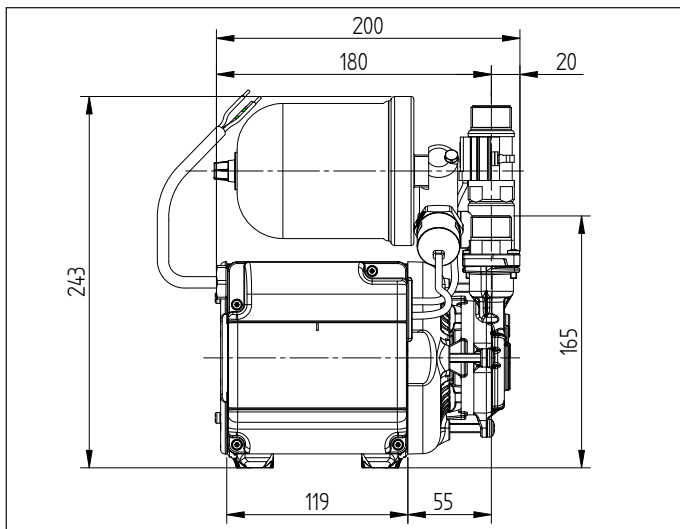

* The maximum pressure that can be applied to the pump under any installation conditions.

** A stored water temperature of 60 °C is considered sufficient to meet all normal requirements and will minimise deposition of scale in hard water areas.

Stuart Turner Limited reserves the right to amend specifications without notice.